

# WISE Activity Booklets

A STEM activity booklet for fun on-the-go learning!  
Made by WISE Kid-Netic Energy

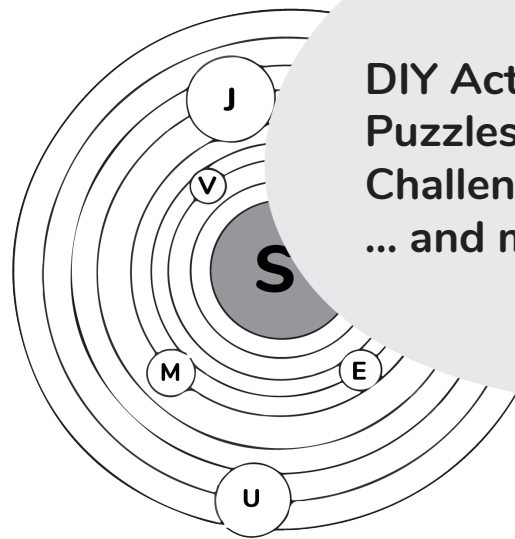

DIY Activities  
Puzzles  
Challenges  
... and more!



University  
of Manitoba

WISE Kid-Netic Energy is a proud member of Actua

A network  
member of  
actua.ca

**actua**  
Youth · STEM · Innovation

With funding from  
**Canada**

## Grade 6 JUNE 2020

Diversity of Living Things - Electricity  
Flight - Exploring the Solar System

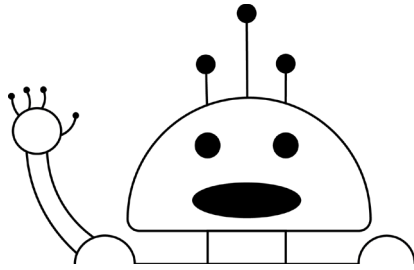

# Hello there!

**WISE Kid-Netic Energy** is a not for profit STEM (Science, Technology, Engineering, and Math) outreach organization at the University of Manitoba. Our organization offers science and engineering workshops, clubs, camps and events to youth from Kindergarten to Grade 12 throughout the province of Manitoba. We reach on average 25 000 to 50 000 youth depending on funding levels. Our approach is simple – present STEM in messy, memorable and engaging ways so Manitoba youth feel motivated to learn more and more. We reach all Manitoba youth, and we particularly target underrepresented youth like girls, indigenous youth and youth facing socio-economic challenges.

All of us at WISE Kid-Netic Energy have been working hard to create these booklets to continue to bring our fun and educational STEM activities to Manitoba youth during these unprecedented times. We are disappointed that we cannot see you in person, and hope that these monthly booklets bring some STEM excitement to your life.

These booklets have been created by our student instructors who are all studying engineering, science, or in another STEM-related field at university. Peek the last page of this booklet to see who created the activities, experiments and recipes within.

All the activities in this booklet are based on the Manitoba Science curriculum. For any teachers viewing this booklet, all the SLO codes are listed at the bottom of each page.

If a link is listed at the bottom of the page, and you have access to the Internet, follow it to check out a video of the activity our instructors have created just for you.

We hope that you enjoy doing the experiments and activities as much as we loved creating them for you.

In this Grade 6 booklet, the science topics you will be exploring are: the diversity of living things, flight, electricity and the solar system!

**Best of luck, and until we see you again,  
the WISE Kid-Netic Energy Crew**

*P.S. If you have any suggestions for activities or experiments you would like us to try, contact us through our website, or social media accounts that are listed on the last page of this booklet.*

## Meet our Amazing Authors!

**Amelia** just completed her first year of the two-year education program in early years education. When she isn't reading, she loves writing lists, running, having quality conversations with friends, knitting and singing show-tunes.

**Amelia**

**Brandi**

**Brandi** just finished her first year in the Faculty of Science and plans to apply to the College of Pharmacy in the future. When she's not studying chemistry she loves to listen to music, hang with her cats, and nap.

**Brenna** is in her second year of mechanical engineering and loves science, especially physics! In her free time she like to paint or draw, see friend , and play with her dog.

**Brenna**

**Sophia**

**Sophia** is in her second year of science and is planning on going into optometry in the future. She loves math and biology, and in her free time loves swimming, reading and trying new foods!

**Zoe** is in her first year of Engineering, and is planning on going into the civil engineering department. She loves math, and in her free time enjoys walking her dog, as well as playing volleyball and ultimate Frisbee.

**Zoe**

## Esiw the Robot

**Esiw** is a friendly robot that loves to help kids learn about computers & coding! Esiw loves to do math, solve problems and make people laugh!

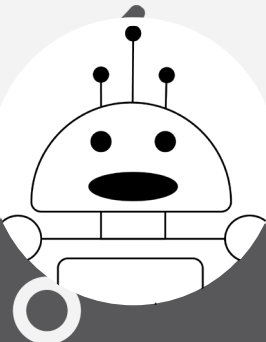

## How to Build a Solar Oven

Scientists and engineers have developed many different ways to generate electricity. Some electricity is renewable, meaning that it comes from a source that occurs naturally and won't run out. Turbines generate electricity from wind and moving water, and solar panels convert energy from the sun into electricity.

Let's build a solar oven to cook marshmallows and demonstrate how much energy sunlight has!

Reading instructions and completing steps in a certain order is how computers read code! Following step by step instructions to complete a task is called an **algorithm**.

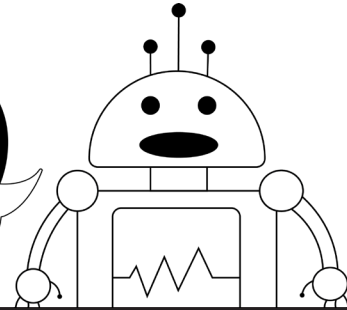

### Materials

- Scissors or Box Cutters
- Aluminum Foil
- Cardboard Box (pizza boxes work best)
- Newspaper or Scrap Paper
- Pie Plate or Clear Glass Dish
- Black Paper
- Tape
- Plastic Wrap or a Clear Plastic Bag
- Oven Mitts
- Marshmallows

### STEP 1

Carefully cut a flap open in the top of the box. Cut along 3 sides, and fold upwards to create a flap. Be sure to leave a border of cardboard from the sides of the box

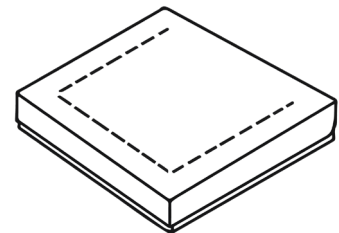

### STEP 2

Cover the inner portion of the flap with aluminum foil, securing it with tape.

*Why? This will reflect the sunlight into the box, and works best if the foil is smooth with no wrinkles.*

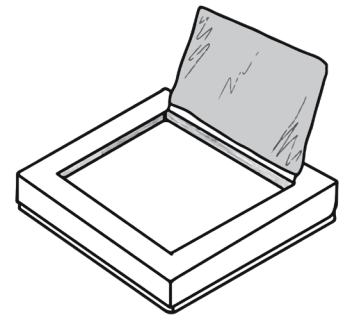

### STEP 3

Use plastic wrap or a clear plastic bag to seal the cut opening and create a 'window'. Seal the edges with tape to make it air tight.

*Why? This window will let sunlight into the oven, while also trapping the heat inside.*

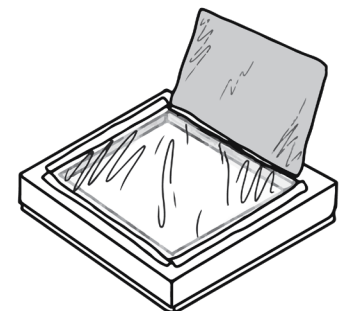

## STEP 4

Line the bottom interior of the cardboard box with black paper.

*Why? Black absorbs light the most of any colour, so this will help the oven heat up faster. We will be placing your marshmallow on this black surface to cook.*

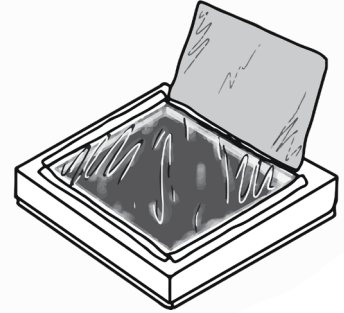

## STEP 5

Place rolled up newspaper or scrap paper inside the box, forming a border around the cooking area. Tape down to hold everything in place.

*Why? This helps to insulate the oven by creating a seal inside the box where the lid closes. The hot air inside cannot easily escape, so it will trap heat well.*

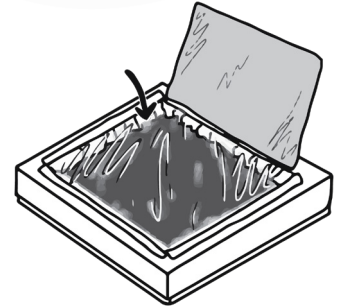

## STEP 6

Place your finished solar oven in a sunny spot, and adjust the aluminum covered flap so that as much sunlight as possible is entering the box through the window.

*You may want to use additional materials to hold the flap in place.*

*Your solar oven will work best when the sun is high overhead, from around 11am to 3pm.*

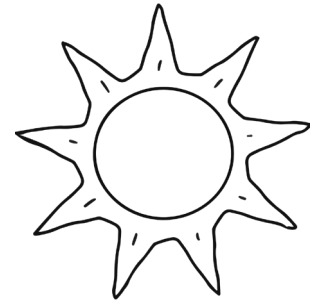

## STEP 7

Now it's time to roast some marshmallows! Place your food on a clear glass dish or metal pie plate, so that the oven doesn't get dirty. Set the dish on the black paper.

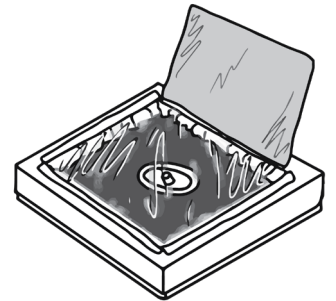

## STEP 8

Once your marshmallows are done, use oven mitts to remove them from the solar oven. Careful, the inside of the oven and the dish will be hot!

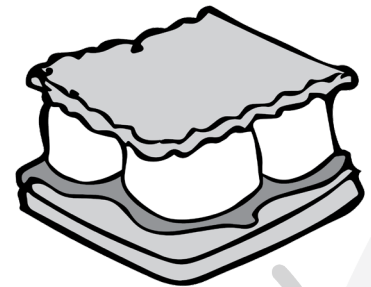

## STEP 9

Enjoy your delicious, solar powered treat! You could even make s'mores with some graham crackers and chocolate too!

# Planets in Our Solar System

## Do you know all of the planets in our solar system?

There's Mercury, Venus, Earth, Mars, Jupiter, Saturn, Uranus and Neptune. But that's pretty hard to remember.

Here's a fun way to remember the planets order!  
**My Very Excellent Mother Just Served Us Nachos**

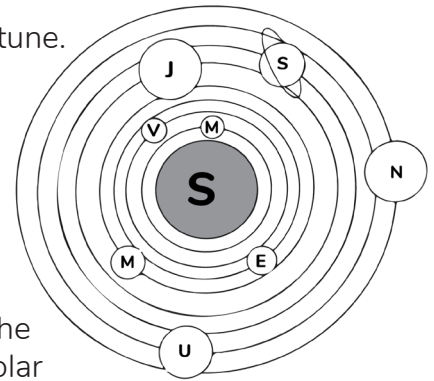

Now you might be thinking, what does this have to do with planets? Now I'm just hungry!

But if you look at the bold letters (MVEMJSUN), the letters that start the words are also the letters that start the names of the planets in our solar system from closest to the sun to furthest!

## How big are the planets in our solar system?

Do you know what the biggest and smallest planets in our solar system are?

Let's put this in perspective, and use some fruit to compare their relative sizes:

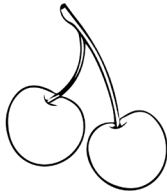

First let's pretend that Earth was the size of a cherry.

If it was, Mercury would be the size of a tiny little peppercorn. ●



Venus would be the size of a large blueberry.

Mars would be the size of a pea. ●



Jupiter would be the size of a watermelon.

Saturn would be the size of a large grapefruit.

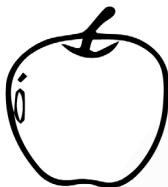
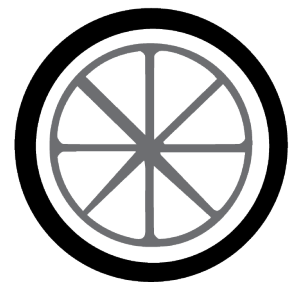

Uranus would be the size of an apple.

And Neptune would be the size of a lemon.

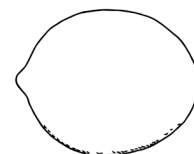

## How far apart are the planets in our solar system?

See if you can find one of each of those food items, or something of similar size, grab a piece of sidewalk chalk and head outside!

The planets in our solar system are not very close together. In fact, there is even a way to compare the distance of the planets to the sun. It's called "Astronomical Units" or AU for short. One AU is equal the distance between the earth and the sun, and is equal to 150 million kilometers (150,000,000km).

We will be using the actual distances to approximate how far apart our fruits and veggies should be apart.

These are the real values on how far apart they are:

Planet	Mercury	Venus	Earth	Mars	Jupiter	Saturn	Uranus	Neptune
Distance from the Sun	0.38 AU	0.72 AU	1.00 AU	1.52 AU	5.20 AU	9.58 AU	19.12 AU	30.20 AU

For this activity we approximated by leaving the decimals as they are. If you want to make a more accurate scale try moving the decimal to the right. Get ready to take 302 steps to get to Neptune! (The steps would be 4, 3, 3, 5, 37, 59, 95, 207 and then 302)

We are going to do this on a smaller scale here. First, grab your chalk and draw a circle on the road or sidewalk outside. This is going to be your sun! Make you sure you have lots of room and ask someone to be your astronaut to look out for any bikes, people or cars!

- First, take 1/2 of a step away from your circle/sun and place your peppercorn. This is Mercury!
- Next, take 1/4 of a step forward from your peppercorn (Mercury) and place your blueberry. This is Venus!
- Now, take another 1/4 of a step from your blueberry, and place your cherry. This is us! Earth!  
\* Note that even though you are only 1/4 of a step away from 'Mercury' you are a full step away from the sun! Which compares to the 1 AU the Earth is from the sun.
- Next is 1 full step from the cherry, place the pea. You've made it to Mars!
- Then take 3 steps to Jupiter, and place the watermelon.
- 5 steps to Saturn, place the grapefruit.
- 9 steps and you've arrived at Uranus, place the apple here.
- And last but not least, 11 steps and you've reached Neptune, put your lime here!

**Congrats space Explorer! You've made your very own solar system!**

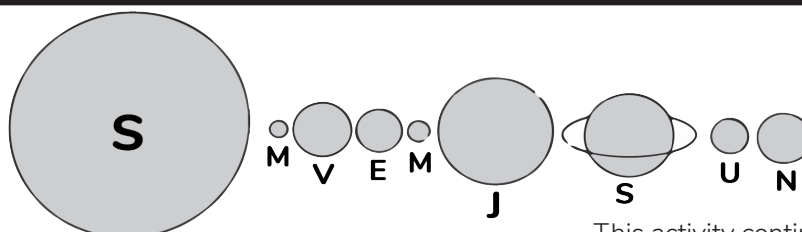

This activity continues on the next page!

## How much do I weigh on other planets in our solar system?

Every planet in our solar system has a different amount of gravity, which means you would have a different weight on each planet. One very important thing to understand is there is a difference between weight and mass. Your weight changes depending on the amount of gravity there is, but the amount of mass remains the same. This is because mass is a measure of the amount of matter, and your matter we are made of does not change with gravity (meaning you will remain the same size regardless of the amount of gravity). Gravity is also that mysterious force that makes everything fall to the ground rather than floating upwards when you drop it. In space there is no gravity and that is why things float around when they are dropped.

To figure out how much you would weigh on other planets you must first figure out your weight in kilograms. Most people know their weight in pounds. It is easy to switch between them, all you have to do is divide your weight in pounds by 2.2 .

Yay! It's time for math! Math is a super important part of coding. So let me help! For example I weigh 110 pounds (on earth), so...

$$110/2.2 = 50 \text{ kg}$$

So my mass is 50 kg!

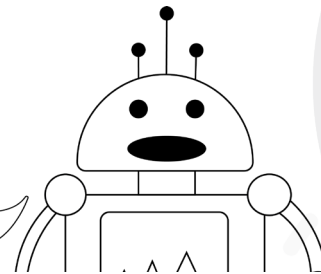

**What is your mass ? \_\_\_\_\_ kg**

Now to figure out your weight on other planets you have to multiply your mass by the amount of gravity, which is measured by its gravitational constant ( $G_c$ ), which compares the amount of gravity on other planets to the amount of gravity on earth. Meaning earth's gravity is  $1G_c$ .

So the equations is **Weight = mass x gravity**

And here is the amount of gravity on other planets :

Planet	Mercury	Venus	Earth	Mars	Jupiter	Saturn	Uranus	Neptune
Gravity ( $G_c$ )	0.38	0.91	1.0	0.38	2.34	0.93	0.92	1.12

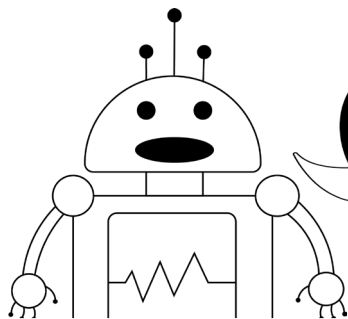

More math! Yippee! So if my mass is 50kg and the gravity on Mercury is  $0.38G_c$  then my weight on Mercury is:

$$50 \times 0.38 = 19\text{kg}$$

Can you calculate your weight on all of the different planets?

Planet	Mercury	Venus	Earth	Mars	Jupiter	Saturn	Uranus	Neptune
Gravity ( $G_c$ )	0.38	0.91	1.0	0.38	2.34	0.93	0.92	1.12
Your Weight								



# Electricity Crossword

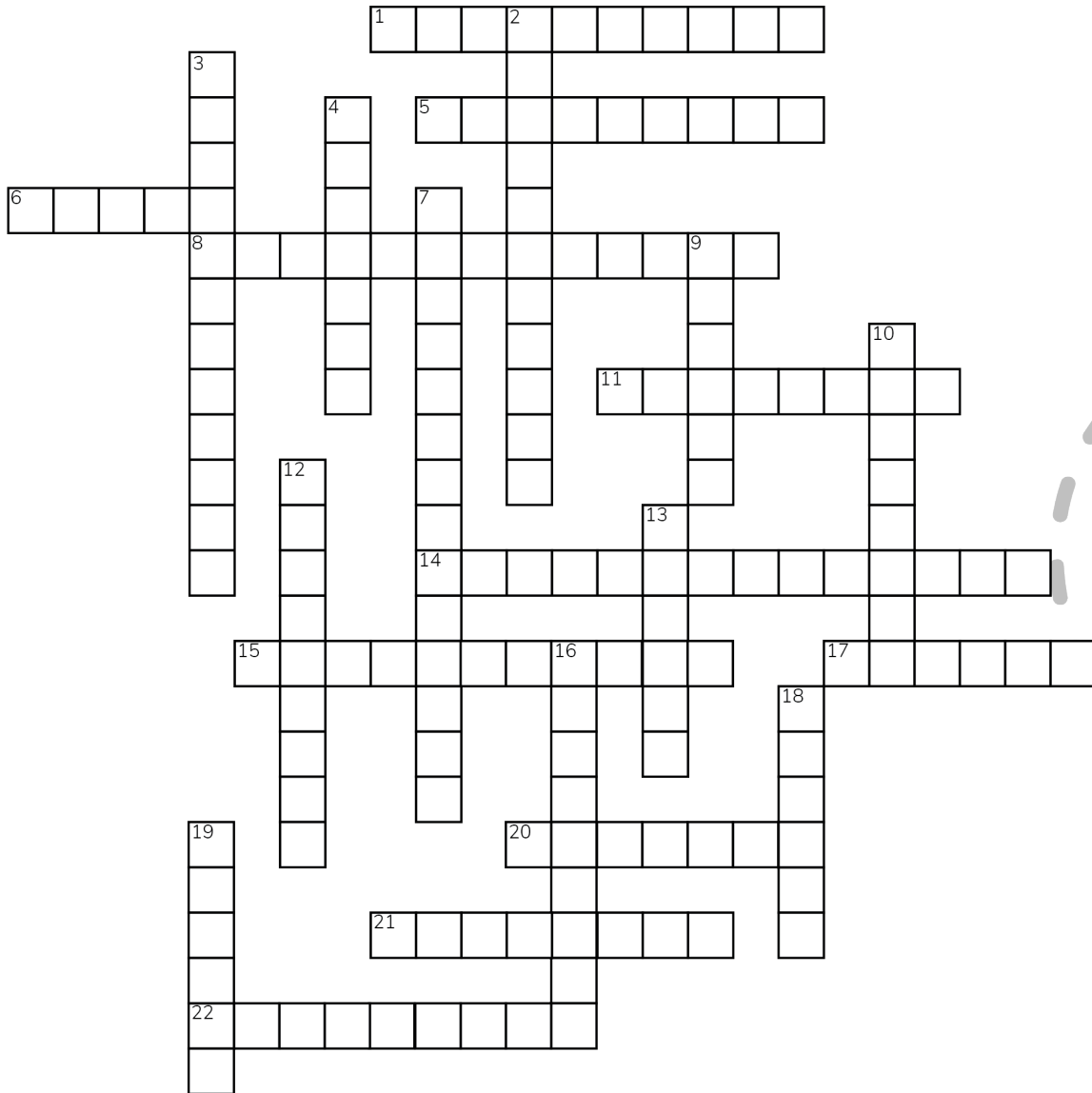

## ACROSS

1. \_\_\_\_\_ appliances run on electricity.
2. If energy is from this source it is not entirely depleted when it is used. E.g. Wind
3. A type of machine that causes vehicles to move.
4. A magnet created by the passage of electricity.
5. The wiring system in a house uses this type of circuit.
6. The earth's surface is one large \_\_\_\_\_ (2 words).
7. A form of energy created by charged particles.
8. All the components in this circuit will share the same current. E.g. String of holiday lights.
9. The flow of electrons moving through a conductor is referred to as \_\_\_\_\_ electricity.
10. Often represented by a plus sign, this type of charge is repelled by itself.
11. A machine that changes mechanical energy into electricity.

## DOWN

1. Energy \_\_\_\_\_ is a measurement of the total amount of energy used to perform a task.
2. A type of energy source that can be used up. E.g. Fossil fuels.
3. A system of conductors that allows for the passage of electricity.
4. A big change.
5. Humans and machines all require \_\_\_\_\_ in order to move.
6. This type of charge is attracted to positive charges.
7. An object that stops the flow of electricity.
8. Rubbing a balloon against hair creates a build up of electrical charges that is known as this type of electricity.
9. An object that allows electrons to flow. Most often made of metal.
10. A device that stops and starts the flow of an electrical current.
11. A property of matter classified as two types.

## Flight Challenge

In this activity you will be building multiple types of paper airplanes and using your knowledge of gravity, lift and drag. You will have to guess which plane will fly the furthest. Follow the instructions on the next few pages to build 4 different airplanes. All you will need is some paper and a pencil.

### Airplane #1

**STEP 1**

Fold the paper in half lengthwise. Then unfold it.

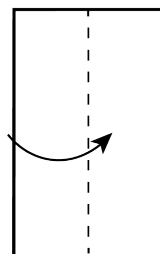

**STEP 2**

Fold the top two corners of the paper down so that the corners meet at the middle of the paper and make a triangle.

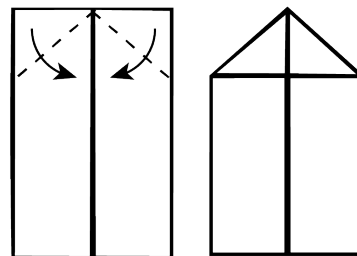

**STEP 3**

Fold each side of the paper inward at an angle so that the outside edges of the triangle now touch and meet in the middle.

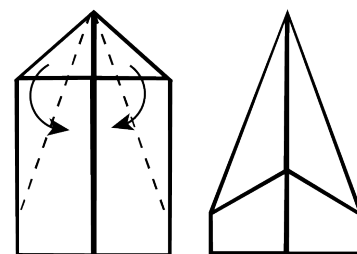

**STEP 4**

Fold your paper in half along the middle line.

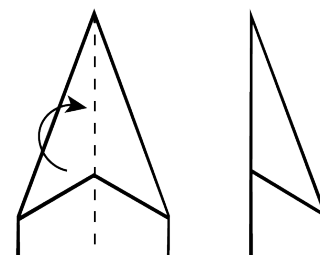

**STEP 5**

Fold both free ends of the paper down to meet the bottom of the paper.

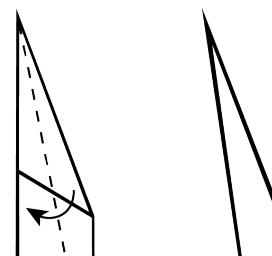

## Airplane #2

STEP 1

Make 2 diagonal folds so that the top edge of the paper lines up with the sides.

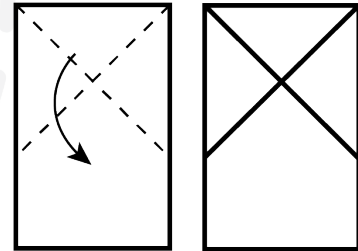

STEP 2

Turn the paper over and make a crease in the paper that's in line with where the two diagonal folds meet.

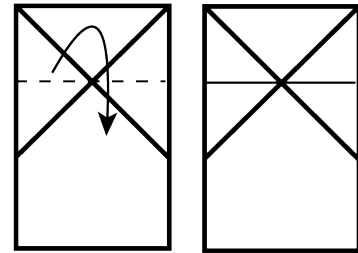

STEP 3

Turn the paper over and push down on the point where all the lines meet. This should make the paper fold towards you. Grab the two ends of the horizontal fold and bring them together to meet in the middle and push it down so that the paper lies flat.

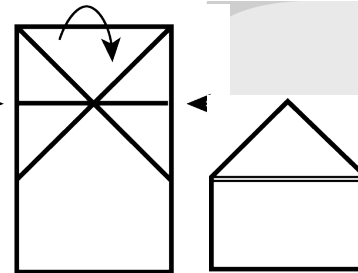

STEP 4

The triangle will have two distinct layers to it. Take one corner of the top layer and fold it upward so the side corner of the triangle touches the top corner. Repeat on the other side.

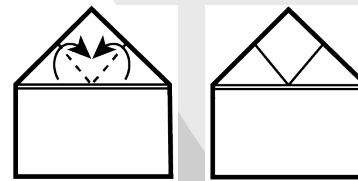

STEP 5

Fold the paper in half along the line of symmetry.

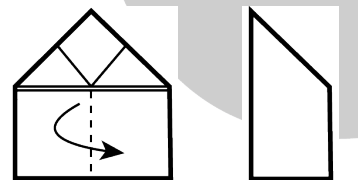

STEP 6

Make a crease about 1.5cm from the center line on both sides and fold outward.

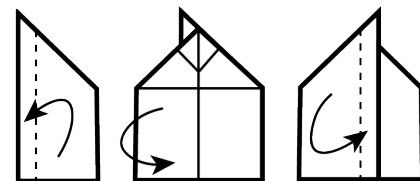

STEP 7

Fold the paper inward about 1.5cm from the edges on both sides. And you're done!

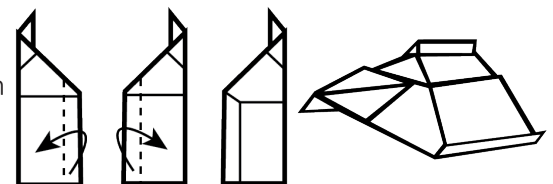

## Airplane #3

**STEP 1**

Make 2 diagonal folds so that the top edge of the paper lines up with the sides.

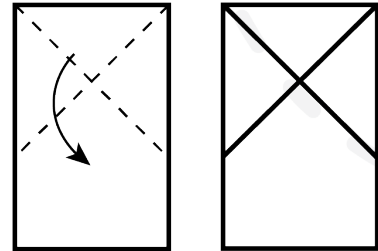

**STEP 2**

Turn the paper over and make a crease in the paper that's in line with where the two diagonal folds meet.

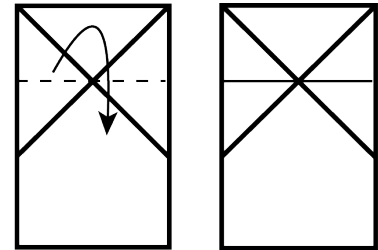

**STEP 3**

Turn the paper over and push down on the point where all the lines meet. This should make the paper fold towards you. Grab the two ends of the horizontal fold and bring them together to meet in the middle and push it down so that the paper lies flat.

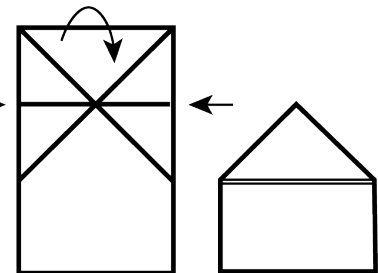

**STEP 4**

Fold up the outer points of the big triangle shape so they line up and create a diamond. Then fold down the tip of the diamond.

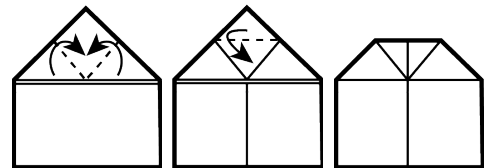

**STEP 5**

Fold the paper in half so the triangle is on the inside of the fold.

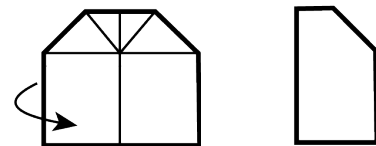

**STEP 6**

Fold the edges outward to create the wings. The body of the plane should be around 1/2 an inch tall.

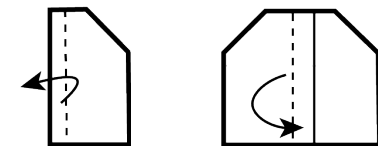

**STEP 7**

Cut two small flaps at the tail end of the wings to change the way you plane moves. And you're done!

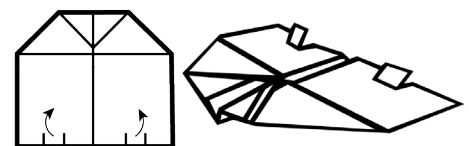

## Airplane #4

### STEP 1

Make 2 diagonal folds so that the top edge of the paper lines up with the sides.

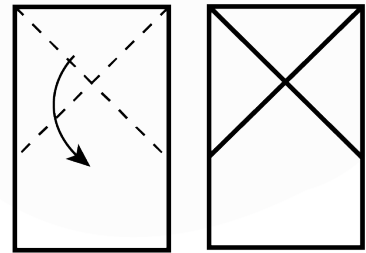

### STEP 2

Turn the paper over and make a crease in the paper that's in line with where the two diagonal folds meet.

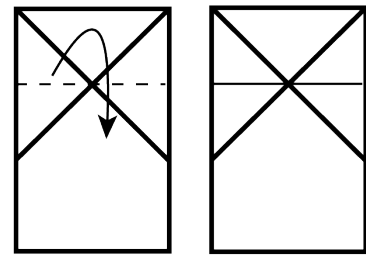

### STEP 3

Turn the paper over and push down on the point where all the lines meet. This should make the paper fold towards you. Grab the two ends of the horizontal fold and bring them together to meet in the middle and push it down so that the paper lies flat.

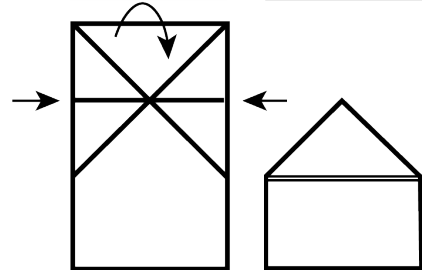

### STEP 4

The triangle will have two distinct layers to it. Take one corner of the top layer and fold it upward so the side corner of the triangle touches the top corner. Repeat on the other side.

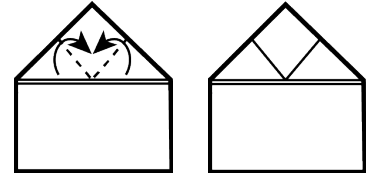

### STEP 5

Fold up the outer edges of the diamond to create a smaller diamond, then fold down the tip of the plane

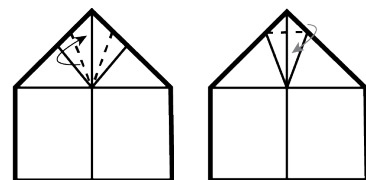

### STEP 6

Turn the plane upside down and fold it in half, then fold down the edges of the wings. And you're done!

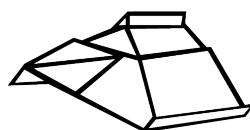
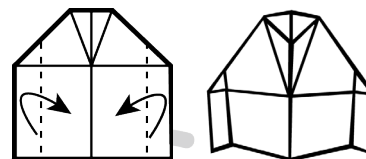

Check out the next page for some tips and tricks!

## General Tips and Tricks

1. Make sure your folds are all crisp and tight. This ensures that your airplanes stay together and has a nice shape.
2. Make the point(s) of your plane sharp. This helps your plane fly better.
3. Angling your hand upwards will make your plane fly higher while keeping it level to the ground will make it go further. Try out different techniques when throwing your plane to make it fly higher, longer or faster!
4. Try making your plane with a heavier paper, like construction paper or cardstock. This will make the plane fly faster because there is less air resistance acting on the plane. But make sure your paper isn't too heavy, otherwise gravity will weigh it down and your plane won't fly!

Did you know that paper planes that are longer fly farther because they are well balanced and can stay straight in the air for a longer period of time?

## Testing Your Airplanes

After you're done building the four different types of paper airplanes, you are going to want to grab some more supplies to be able to measure your results!

You're going to need: a pencil, a stop watch (or some kind of timer), and a measuring tape or meter stick.

Things you will be tracking :

- **Distance**, measured in meters: mark a starting point that you will use for all of your trials. This is where you will start measuring from for each trial. After each trial, measure the distance from your fixed starting point to the furthest point on your plane, where it lands on the ground.
- **Speed**, measured in seconds: Keep track of how long your plane is in the air from the moment it leaves your hand, until the moment it touches the ground. Restart your timer for each trial.
- **Average**: The average can be calculated by adding up all of the results from all three trials, and dividing this number by the number of trials it took (in this case three).

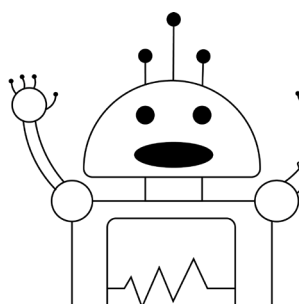

I love math! Math is a super important part of coding! Maybe I can give you a hand calculating an average! For example if we threw the same plane three times and it went 5.5 m, then 6.0 m on the second throw and 5.8 m on the third throw. We would add:

$$5.5\text{m} + 6.0\text{m} + 5.8\text{m} = 17.3\text{m}.$$

Then we would divide that by the number of trials (3) to get:

$$17.3\text{m}/3 = 5.77\text{m}.$$

So 5.77m is the average!

Airplane Example	Distance (m)	Speed (s)
Trial #1	5.5m	10s
Trial #2	6.0m	8s
Trial #3	5.8m	9s
Average of all trials	5.77m	9s

## Record Your Data Here:

Airplane # 1	Distance (m)	Speed (s)
Trial #1		
Trial #2		
Trial #3		
Average of all trials		

Airplane # 2	Distance (m)	Speed (s)
Trial #1		
Trial #2		
Trial #3		
Average of all trials		

Airplane # 3	Distance (m)	Speed (s)
Trial #1		
Trial #2		
Trial #3		
Average of all trials		

Airplane # 4	Distance (m)	Speed (s)
Trial #1		
Trial #2		
Trial #3		
Average of all trials		

## What Am I?

Read about the different kingdoms that organisms can be sorted into and use that info to sort the animals on the next page into their proper kingdoms. Cut out the animals and glue them in their proper kingdom.

- **Animals:** There are so many types of animals that come in all shapes and sizes! Animals are made up of millions of cells. They cannot make their own food so they eat plants and other animals for energy.
- **Plants:** Plants are made of many cells, but theirs are different than humans'. Their cells help them make their own food from sunlight! They grow in the ground and need lots of water.
- **Fungi:** These are like plants, but they cannot make their own food! Instead they get their nutrients by decomposing or breaking down decaying plants and other organic materials around them/in the soil.
- **Bacteria:** These are very tiny, just one cell! They like to live almost anywhere, even on our hands and in our stomachs. Some can be harmful and cause infections, while some can be helpful like in medicine!

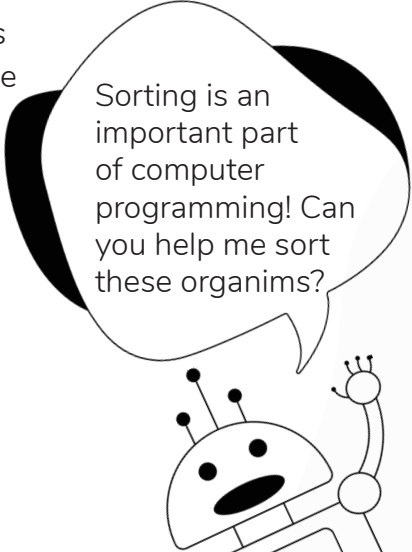

Sorting is an important part of computer programming! Can you help me sort these organisms?

<b>ANIMALS</b>	<b>PLANTS</b>
<b>FUNGI</b>	<b>BACTERIA</b>



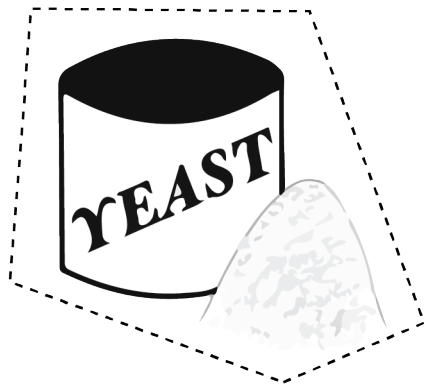
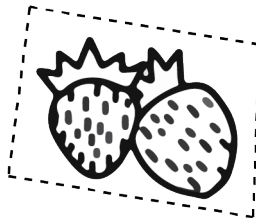
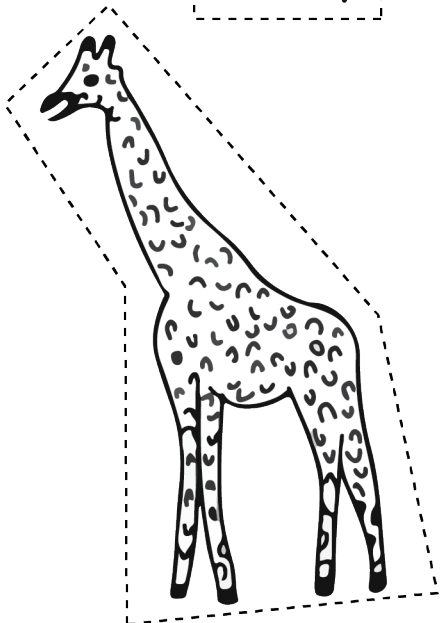
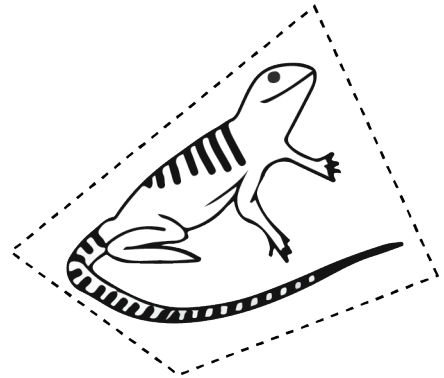
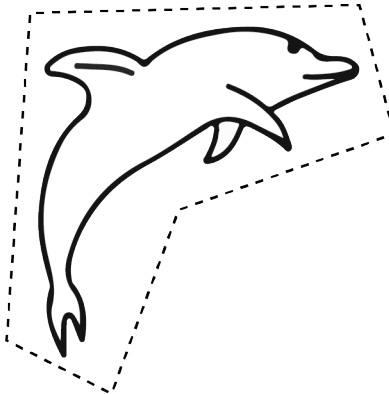
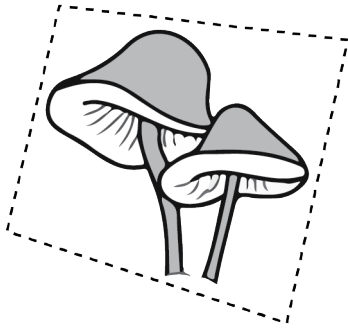
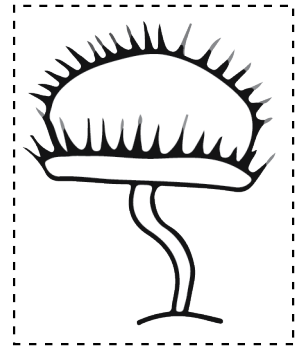
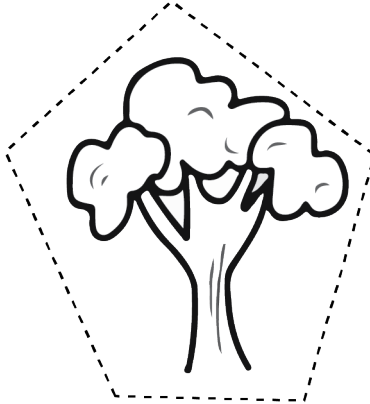
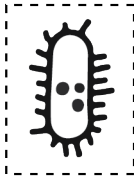
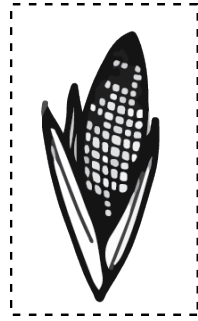
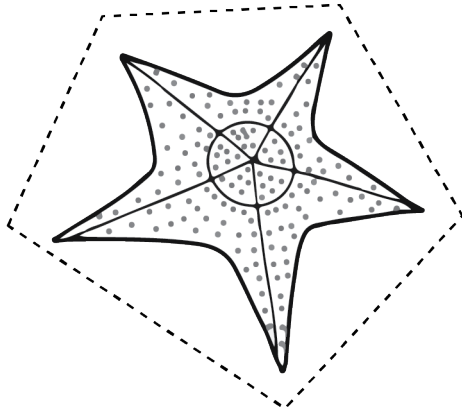

This page was intentionally left blank because the other side is meant to be cut up.

# Answer Keys

## Electricity Crossword (page 9)

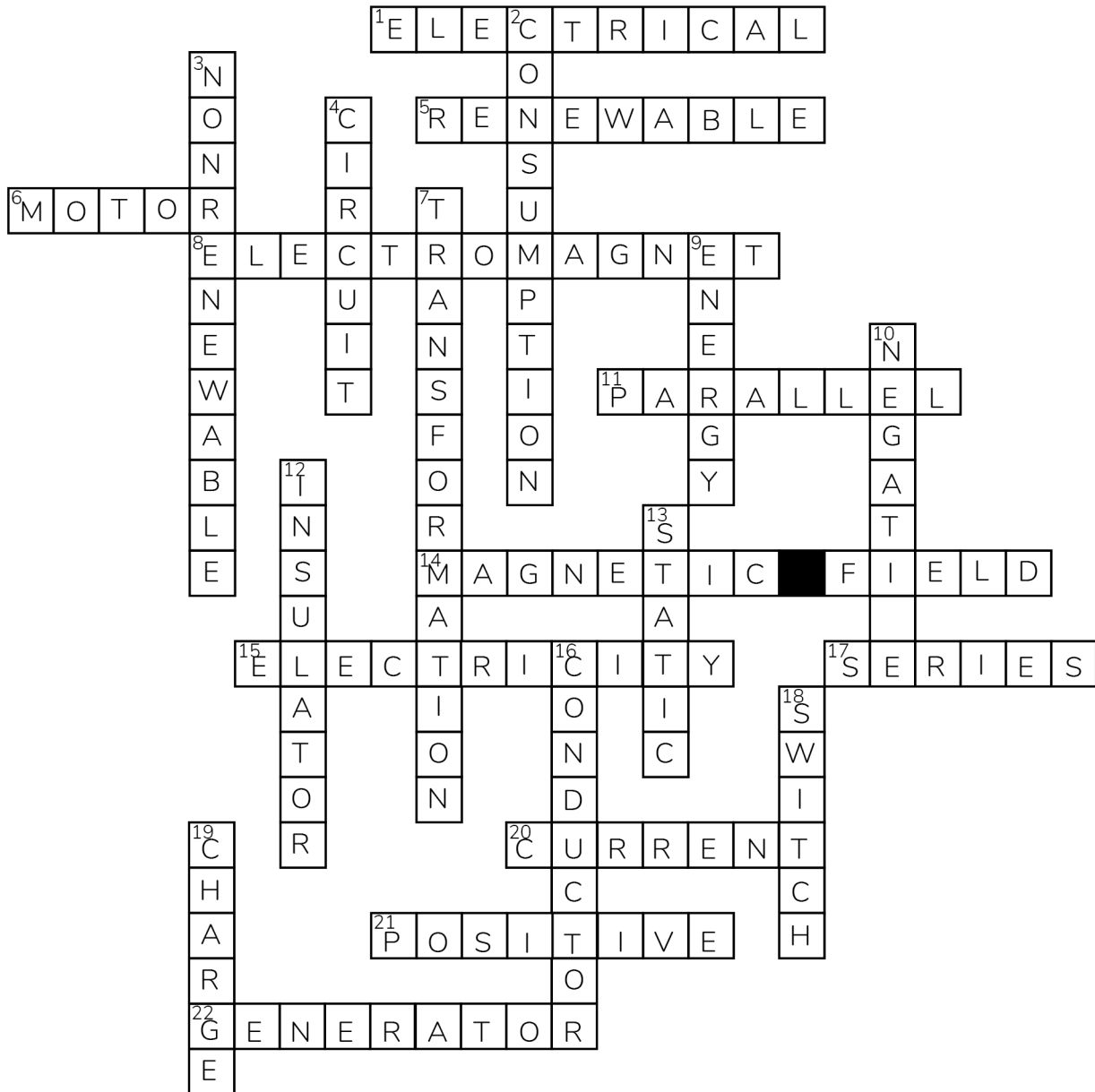

## What Am I (page 16)

Animals : giraffe, dolphin, sea star, lizard

Plants : potted plant, corn, tree, strawberry, venus fly trap

Fungi : mushrooms, yeast

Bacteria : 2 bacterial cells

# Thanks to our Amazing Sponsors!

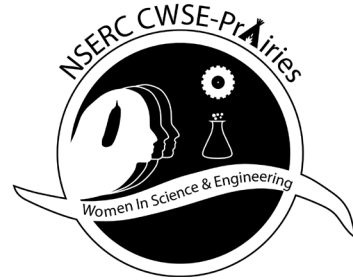

MOTOROLA SOLUTIONS  
FOUNDATION



ENGINEERS  
GEOSCIENTISTS  
MANITOBA

green équipe  
team verte  
.....  
Manitoba 



**NSERC  
CRSNG**



UM | Price Faculty  
of Engineering



faculty of SCIENCE  
discover the unknown + invent the future

WISE Kid-Netic Energy is a proud member of Actua.

A network  
member of  
actua.ca

**actüa**  
Youth · STEM · Innovation

With funding from  
**Canada**

For more fun, STEM content, visit us at [wisekidneticenergy.ca](http://wisekidneticenergy.ca) and follow us on social media!



@wisekidnetic

WISE Kid-Netic Energy